



Specialist for Pumping Technology

INNOVATION
EFFICIENCY
QUALITY



SOLAR POWER MARKET

Concentrated Solar Thermal Power

For more than 60 years the name Ruhrpumpen™ has been synonymous worldwide with innovation and reliability for pumping technology

Ruhrpumpen is an innovative and efficient centrifugal pump company that offers operators of Pump systems a wide range of quality products. Ruhrpumpen is committed to worldwide excellence, with a complete range of pumps to support core markets such as Petrochemical, Oil & Gas, Power, Heavy Industry Applications, Mining, and Water. Our broad product line complies with the most demanding quality standards and industry specifications such as: API, ANSI and Hydraulic Institute Standards.

Ruhrpumpen is a vertically integrated company with its own foundry, machine shop, pump manufacturing plants and service centers. With strategically located manufacturing plants, operating offices and service centers in many parts of the world, Ruhrpumpen truly is a global pump company which also has the strength to focus on the local necessities of each client.

Pumps for the Solar Market

All around the world, total consumption of marketed energy is increasing exponentially. Until today, the principal source of energy has been fossil fuels, such as coal, petroleum, and natural gas. The escalating cost of fossil fuels, their availability, and environmental concerns, are forcing the power industry to find alternative sources of energy.

Solar energy is the most abundantly available source of energy on Earth. The amount of solar radiation that the earth receives in one hour equates to more energy than the world consumes in a year. Pumps play an important role in converting this energy into electricity.



A Pumping Solution for Every Application

Converting sunlight, or sun heat, into electricity can be accomplished by two different technologies: Photovoltaic or Concentrated Solar Power (CSP). Pumps play an important role in Concentrated Solar Power and Ruhrpumpen is able to supply the pumping solution for every application for this type of clean energy production.

Some of the pumping applications involved in solar energy technology are:

- For the heat transfer fluid (HTF), heavy-duty, radially split between bearings pumps.
- For molten salt, vertical high pressure pumps.
- Circulating water pumps, either vertical or horizontal.
- Boiler feed water pumps.
- Condensate extraction pumps.
- Auxiliary service pumps.

Concentrated Solar Power (CSP)

There are various methods of concentrating radiation from the Sun in order to produce electricity. The sun heats a medium which heats water directly or indirectly. The water produces steam through heat exchangers and it causes a conventional steam turbine generator to produce clean electricity.

These are some technologies of Concentrated Solar Power Generation where Ruhrpumpen pumps can be used:

- Linear Fresnel Reflectors
- Parabolic Trough
- Central Tower
- Beam Down



LINEAR FRESNEL REFLECTORS

Reflectors or mirrors that reflect solar rays onto tubes which are in an elevated receiver. Through the tubes flows a heat transfer fluid (synthetic oil for example) which collects the heat of the sun. Heavy-duty pumps that can handle temperatures as high as 400 °C (750 °F) are required for this fluid.

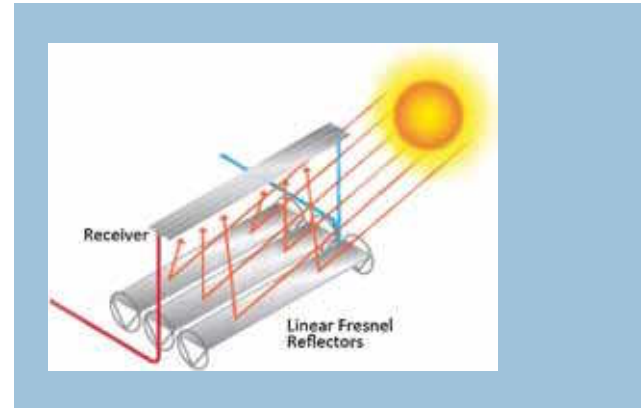

PARABOLIC TROUGH

Parabolic mirrors which track the sun and concentrate the solar energy onto receiver tubes placed in the trough's focal line. Heat transfer fluid is also used in this type of technology.

Both processes can include a molten salt storage system. Vertical molten salt pumps would be required for this storage system. Superheated feed-water, condensate and cooling water pumps are also required for the second part of the concentrated solar thermal plant. Ruhrpumpen has all the pumps suitable for these applications.

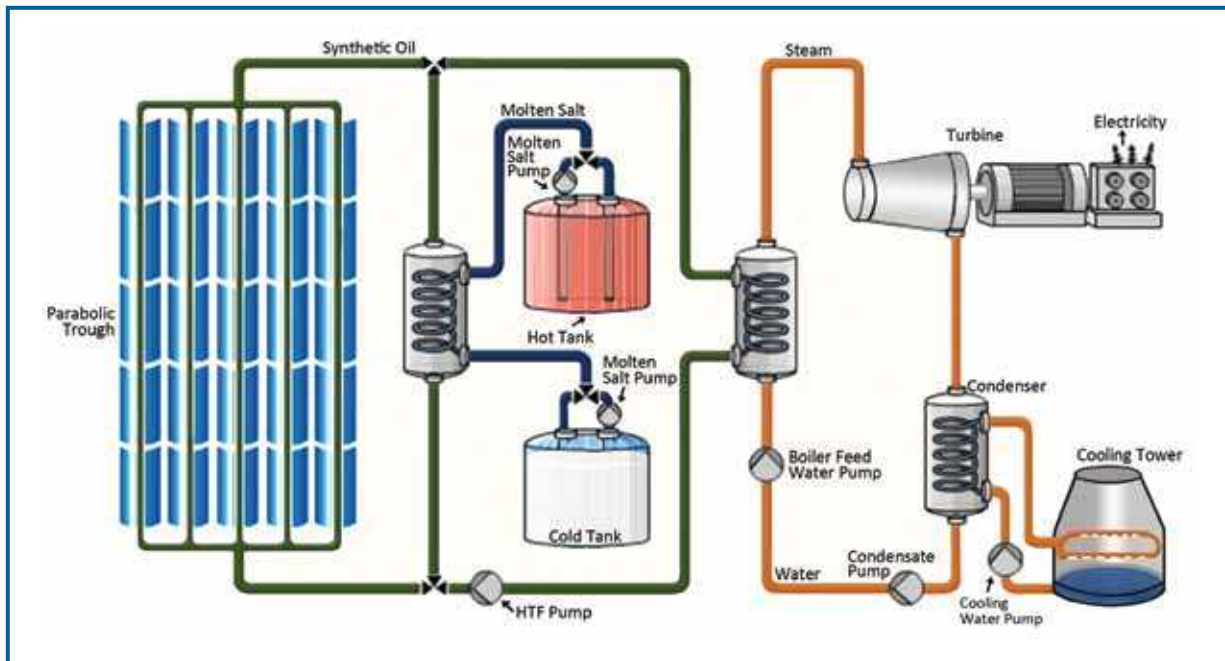
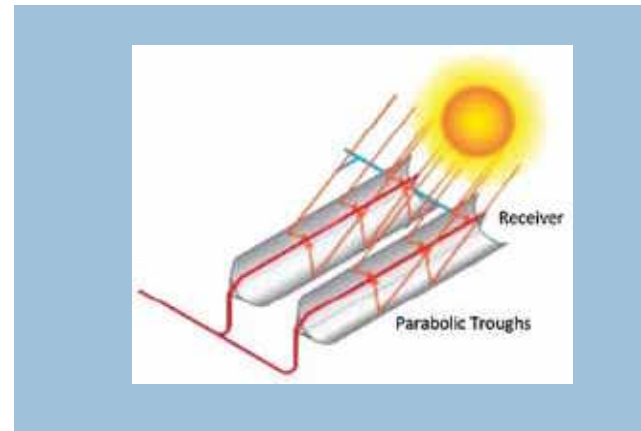

Process at a Parabolic Trough Field with Molten Salt Storage System.

CENTRAL TOWER

A circular array of mirrors (heliostats) reflect the sun's rays to a receiver on top of a tower where the heat is concentrated. Molten salt acts as the heat transfer fluid and also as the heat storage fluid.

Molten salt vertical pumps which handle temperatures up to 600 °C (1,100 °F) are required for this process. Superheated feedwater, condensate and cooling water pumps are also required for this technology. Ruhrpumpen has all the pumps suitable for these applications.

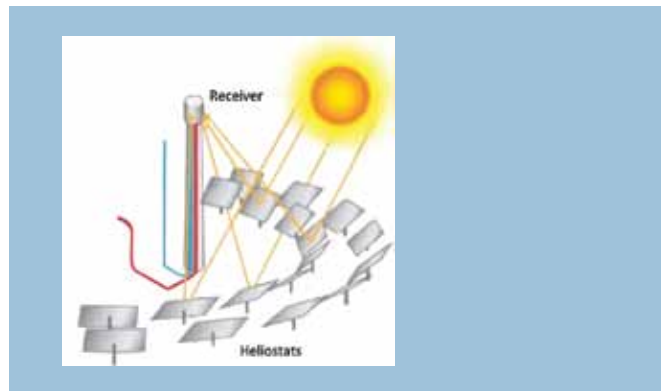

BEAM DOWN

A reflector placed in the top of a tower that concentrates the light down to another receiver at ground level where the media is heated. The process before this is the same as the central tower and requires the same types of pumps.

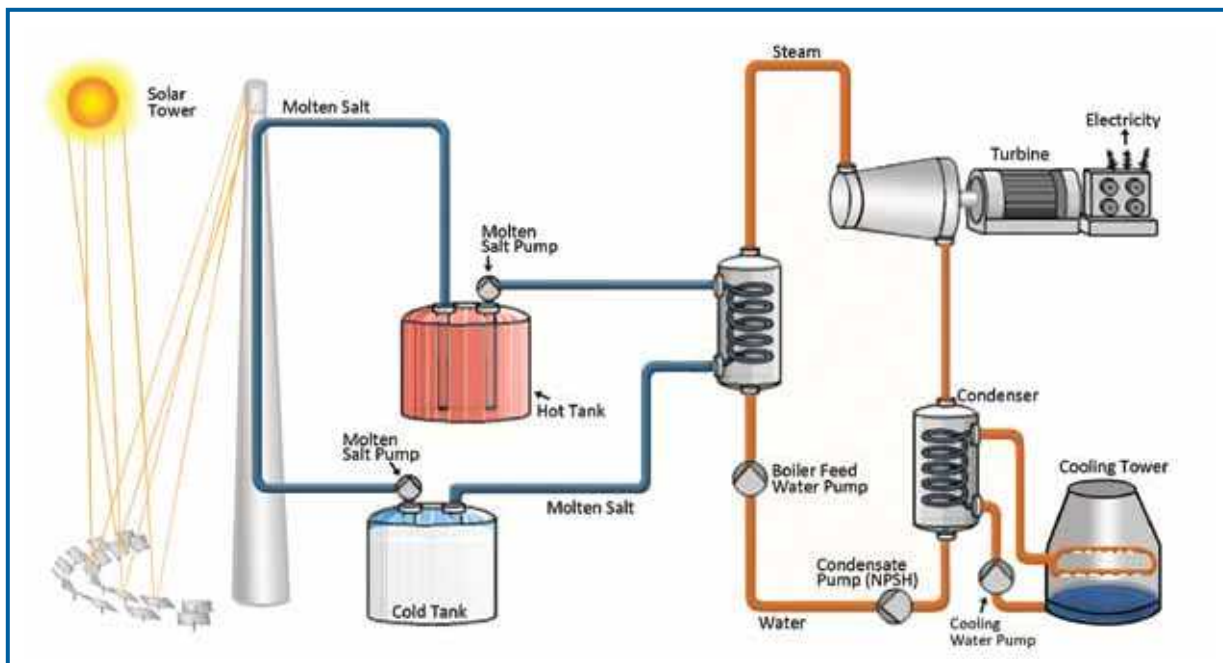
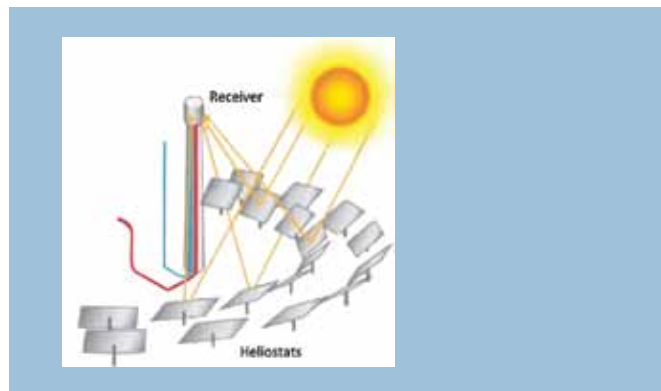

Process at a Solar Central Power Tower.

Ruhrpumpen Products Suitable for Concentrated Solar Power (CSP)

MOLTEN SALT PUMP - VLT

The VLT is a vertical process pump of the "double casing" type as defined by API-610. This pump is the perfect choice to be used in molten salt applications. Molten salt is a salt in the liquid phase used as a heat transfer fluid and as a heat storage fluid in concentrated solar power fields. VLT pumps are placed in the top of the tank to transport the molten salt through the field. The pump must be able to handle temperatures up to 600 °C (1,100 °F) and with special materials, the VLT Type can handle that.

PRODUCT DESCRIPTION

- Double casing vertical process pump (type VS6).
- Low NPSH "Shockless Entry" first stage impeller.
- Integral fabricated column support bearings.
- Collet, or ring and key impeller mounting.
- One-piece shaft construction for shaft lengths to 20 ft (6 m).
- Rigid four-piece coupling.
- Fabrications manufactured using ASME Section IX code qualified welders for API applications.
- Wide range of hydraulic designs to suit most applications.
- Choice of bearings and mechanical seals.
- Pump mounted thrust bearing when required.
- Tank or sump mount options available.

PERFORMANCE DATA

Capacity	up to 7,000 U.S. gpm	1,600 m ³ /h
Head	up to 4,900 ft	1,500 m
Pressure	up to 2,020 psi	140 bars
Temperature	-320 °F to 1,100 °F	-196 °C to 590 °C
Horsepower	1,500 HP	1,200 kW

Note: For pump operations outside this range, please contact a Ruhrpumpen representative.

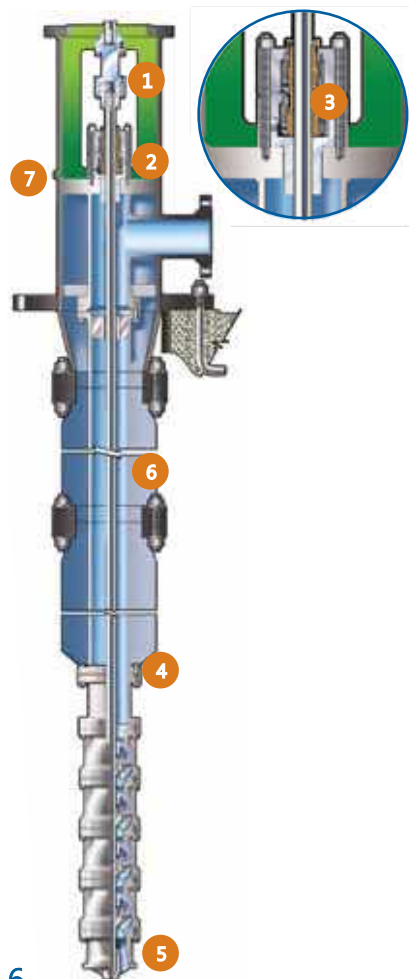

VLT PUMP CHARACTERISTICS FOR MOLTEN SALT APPLICATIONS

- 1 The head is fitted with an all steel rigid 4 piece pump to motor coupling. It has a spacer which can be removed without disturbing the motor or pump connections. The spacer is long enough to allow replacement of the mechanical seal as a single cartridge.
- 2 The mechanical seal is located in full flow of discharge for positive lubrication-cooling and is inherently self-venting and self-cleaning.
- 3 Packing in the stuffing box. Bleed-off stuffing boxes are also available.
- 4 The O-ring gaskets throughout allow metal-to-metal rabbeted fits between all components, which prevents possible leaking.
- 5 Graphite-babbeted alloy bearings are standard throughout this pump.
- 6 Bleed off pipes.
- 7 Special ribs to support the column to prevent distortion from the heat.
 - STL LC or Stainless Steel depending on the temperature that will be reached.
 - Metal "C" rings are used in lieu of o-rings.



VLT

To see more features of this pump, please see the VLT brochure, or contact a Ruhrpumpen representative.

HTF MAIN PUMP – HVN & J LINE

The HVN Type pumps are heavy-duty centrifugal process pumps for universal applications. The single stage, double suction design pump meets the stringent specifications of API Standard 610. Due to the variable operation and the daily start and stop in a concentrated solar power field, along with the temperatures and pressures that the heat transfer fluid can reach, a robust pump like the HVN is required. With special materials and considerations, this pump is the perfect choice for this application and Ruhrpumpen can supply it for your concentrated solar field.

PRODUCT DESCRIPTION

- Radially split, horizontal single stage centrifugal pump (type BB2).
- Centerline mounted.
- Double volute casing.
- Thrust compensation by double suction enclosed impeller.
- Top-Top nozzle arrangement. Other arrangements on special request.
- Modular design system.
- Materials of construction per API 610. Other materials on request.

PERFORMANCE DATA

Capacity	up to 30,000 U.S. gpm	6,814 m ³ /h
Head	up to 2,000 ft	610 m
Pressure	up to 1,813 psi	125 bar
Temperature	-300 to 850 °F	-184 to 450 °C

Note: For pump operations outside this range, please contact a Ruhrpumpen representative.

CHARACTERISTICS

- 1 Top-top arrangement.
- 2 All flanged connections available.
- 3 Ample sized Stuffing Box.
- 4 Cooling for both the Sealing Chambers and Bearing Housings available.
- 5 Case/Case Cover, metal-to-metal contact.
- 6 Centerline Mounted Case.
- 7 Single-piece bearing housing, air cooled.
- 8 Anti-friction bearing.
- 9 Sleeve and tilting pad bearings available.
- 10 Easy inspection and maintenance.
- 11 Standard integrally flanged drain line.
- 12 Pump is self-venting.
- 13 Double Suction Impeller.
- 14 Balancing with semi-fitted key.
- 15 360 Degree Bearing Housing Supports.

HVN & J LINE CHARACTERISTICS FOR HTF APPLICATIONS

- Chrome steel material for the case and impeller (C6 material selection).
- Warm-up lines from pump to pump (in a multi-pump solar concentrated field system).
- Various Cooling Options available for Bearings and Seals per API 610.
- The pump instrumentation consists of vibration probes mounted in x-y direction on each bearing bracket of the pump.
- Digital vibration analyzer.
- Temperature measurement devise for pump bearing and stuffing box.
- Electronic heating system for the pumps before restart.
- Noise and temperature protection hood.
- Pressurized seal system API Plan 54 with the same HTF fluid as buffer medium.
- Double bellow seal.

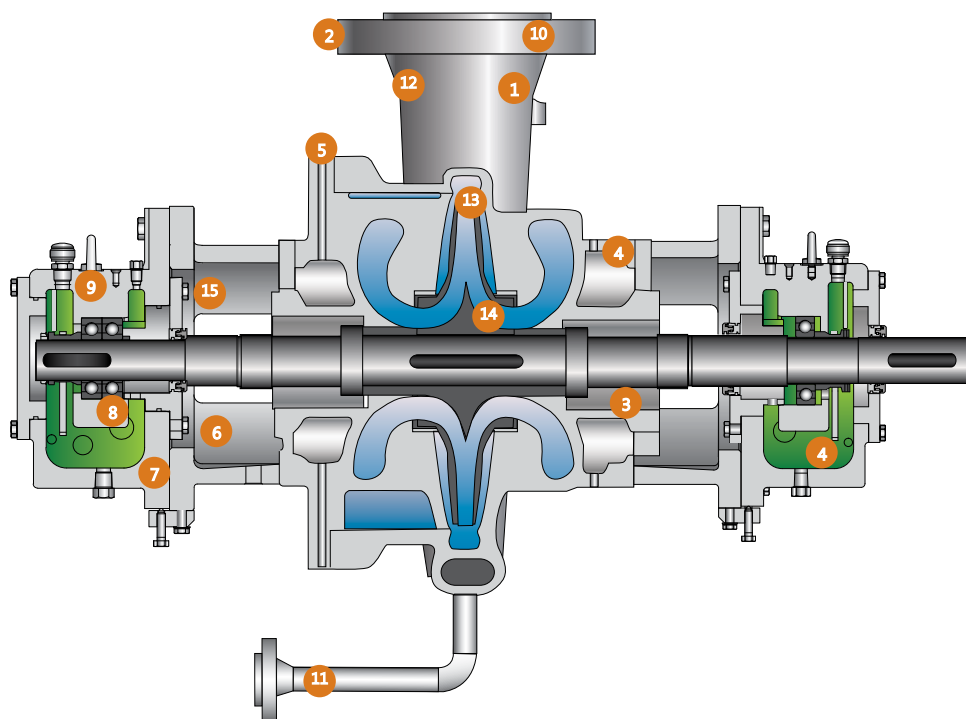

To see more features of this pump, please see the HVN & J Line brochure, or contact a Ruhrpumpen representative.

HTF AUXILIARY PUMP – SCE

The SCE is a heavy duty, single stage, centrifugal overhung process pump built in accordance with the latest edition of API 610. Since this pump can meet the pressures and temperatures that the heat transfer medium generates in a concentrated solar field service, it makes for a good fit as an auxiliary service pump for this application.

PRODUCT DESCRIPTION

- Horizontal single stage, centerline mounted, back pull-out, radially split, end suction, top discharge, heavy duty centrifugal process pump (type OH2).
- Process Design.
- Single Suction.
- Designed to meet full API 610 pump standards, Latest Edition.



SCE

PERFORMANCE DATA

Capacity	up to 12,340 U.S. gpm	2,800 m ³ /h
Head	up to 1,300 ft	400 m
Discharge flange	1" to 12"	
Pressure	up to 1,300 psi	90 bar
Temperature	-58 to 850 °F	-50 to 450 °C

Note: For pump operations outside this range, please contact a Ruhrpumpen representative.

CHARACTERISTICS

- 1 75 volute casing pump sizes for 50 and 60Hz operation, and 118 hydraulic combinations possible. Centerline discharge nozzles from 1" to 12", in compliance with API 610, latest Edition.
 - 2 The seal chamber is larger than API dimensions and will accept all mechanical seal arrangements.
 - 3 Case / Case Cover with metal-to-metal contact.
 - 4 The shaft is designed with a larger diameter and minimum length to reduce shaft deflection.
 - 5 Antifriction bearings.
 - 6 Bearing Bracket fins and standard fan cooling.
 - 7 Piping connections are integrally flanged.
 - 8 Bearing Bracket provided with sight glass and constant level oiler for visual inspection and oil sampling.
- Centerline mounted case, and features a back-pull-out design for easy maintenance.

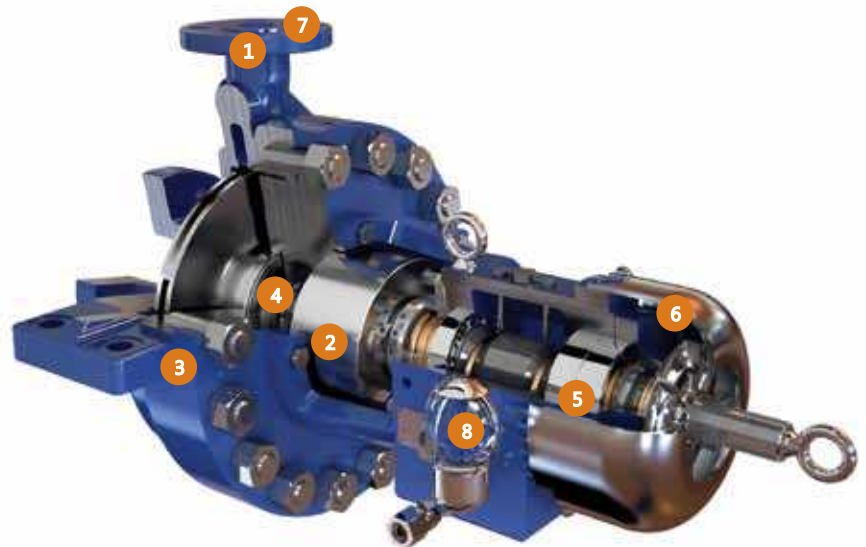

To see more features of this pump, please see the SCE brochure, or contact a Ruhrpumpen representative.

BOILER FEED WATER PUMP – HSM

The HSM is a Heavy Duty centrifugal, Horizontally Split multistage volute pump ideally suited for high pressure applications such as boiler feed. It is perfect for power plants in concentrated solar power fields.

PRODUCT DESCRIPTION

- Multistage horizontal centrifugal pumps (type BB1).
- Two or four stages, double volute pump.
- Horizontally split casing, side/side suction and discharge flanges.
- Enclosed impeller.
- Short, heavy shafts, elastic seal o-rings, axial and radial balance.
- Wear rings, stage pieces, diaphragm and stuffing box break- down bushings are provided with elastic seal o-rings.
- Pump feet beneath bearings to maintain coupling alignment at higher temperatures.
- Self Venting.

PERFORMANCE DATA

Capacity	up to 2,000 U.S. gpm	454 m ³ /h
Head	up to 2,200 ft	670 m
Pressure	up to 740 psi	51 bar
Temperature	250 °F	121 °C

Note: For pump operations outside this range, please contact a Ruhrpumpen representative.

CHARACTERISTICS

- Oil lubricated ball bearing double row angular contact thrust bearings are water cooled.
- Stuffing Box allows for packing or mechanical seal.
- Vent on suction of first stage.
- Opposed impellers for axial hydraulic balance.
- Oil lubricated ball radial bearing.
- Elastic seal o-rings on casing rings, stage pieces and breakdown bushings.
- Staggered volutes hold pump radial balance.
- Renewable wearing rings. Tongue and groove joint in lower half casing. Dial balance.
- Pump feet. Beneath bearings. Near horizontal centerline permits high temperature operation without coupling misalignment.
- Water Cooled Stuffing Box (Optional).
- UNB optional.



HSM

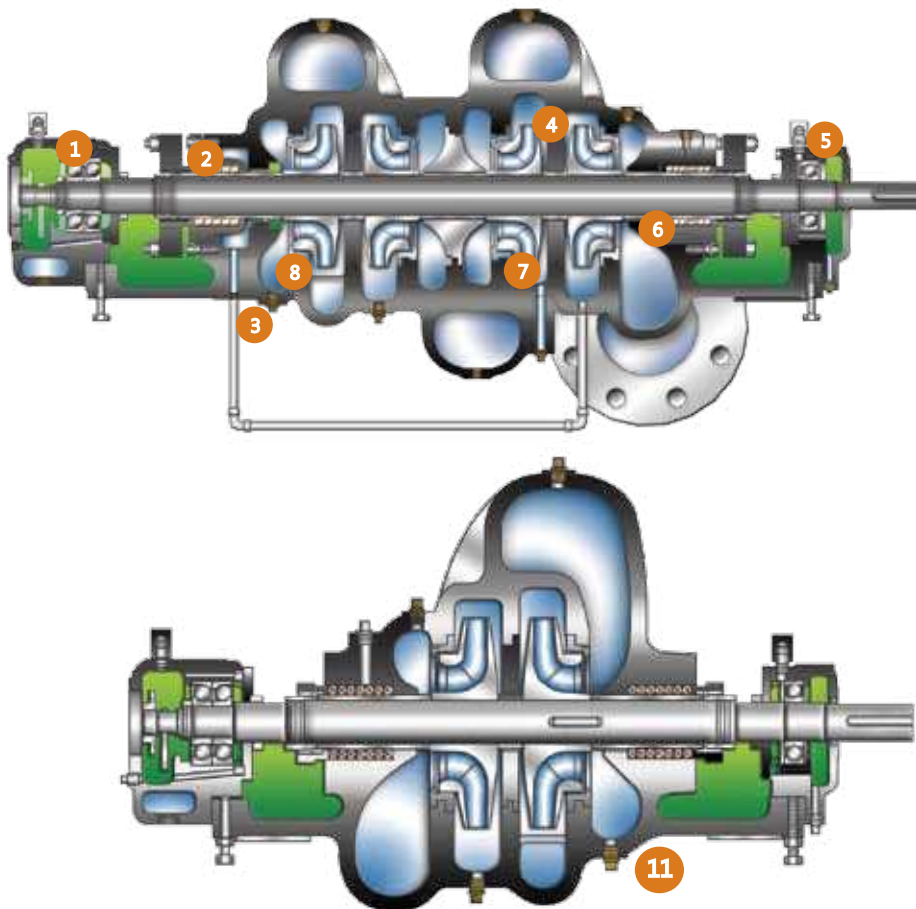

To see more features of this pump, please see the HSM brochure, or contact a Ruhrpumpen representative.

CONDENSATE EXTRACTION PUMPS – VLT

The VLT is a vertical process pump of the “double casing” type as defined by API-610. The special first stage allows operation with extremely low NPSH requirements while running at optimum speeds. This makes this pump the perfect fit as a condensate pump for use in a concentrated solar power field.

PRODUCT DESCRIPTION

- Double casing vertical process pump (type VS6).
- Low NPSH “Shockless Entry” first stage impeller.
- Integral fabricated column support bearings.
- Collet, or ring and key mounted impellers.
- One-piece shaft construction for shaft lengths to 20ft (6m).
- Rigid four-piece coupling.
- Fabrications manufactured using ASME Section IX code qualified welders for API applications.
- Wide range of hydraulic designs to suit all applications.
- Choice of bearings and mechanical seals.
- Pump mounted thrust bearing when required.
- Tank or sump mount options available.

PERFORMANCE DATA

Capacity	up to 7,000 U.S. gpm	1,600 m ³ /h
Head	up to 4,900 ft	1,500 m
Pressure	up to 2,020 psi	140 bars
Temperature	-320 °F to 1,100 °F	-196°C to 590 °C
Horsepower	1,500 HP	1,200 kW

Note: For pump operations outside this range, please contact a Ruhrpumpen representative.

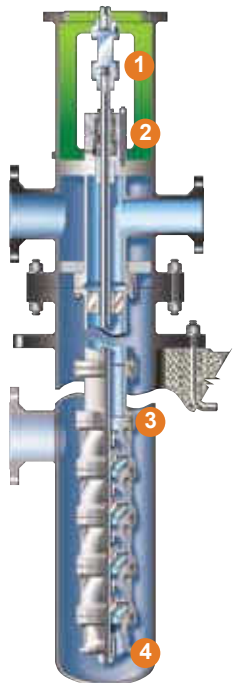

CHARACTERISTICS

- 1** The head is fitted with an all steel rigid 4 piece pump to motor coupling. It has a spacer which can be removed without disturbing the motor or pump connections. The spacer is long enough to allow replacement of the mechanical seal as a single cartridge.
- 2** The mechanical seal is located in full flow of discharge for positive lubrication-cooling and is inherently self-venting and self-cleaning. Water jacketed, bleed-off stuffing boxes are also available.
- 3** The O-ring gaskets throughout allow metal-to-metal rabbeted fits between all components, which prevents possible leaking.
- 4** Graphite-babbeted alloy bearings are standard throughout.

To see more features of this pump, please see the VLT brochure, or contact a Ruhrpumpen representative.



VLT

CIRCULATING WATER PUMPS – VCT

The VCT is a single or multi-stage mixed flow, vertical centrifugal pump mainly used for water applications. Because of its mixed flow impeller, this pump handles large volumes of liquids with relatively low heads, making it ideal for circulating water applications.

PRODUCT DESCRIPTION

- Single or multi-stage mixed flow, vertical centrifugal pump (type VS1).
- Semi-open impeller allows handling of large solids (closed impeller also available).
- Large bowl passages for better efficiency.
- Threaded or flanged column (depending on size) with water or oil lubrication.
- Single or double suction first stage available.

PERFORMANCE DATA

Capacity	up to 220,000 U.S. gpm	50,000 m ³ /hr
Head	up to 575 feet	175 m
Pressure	up to 160 psi	11 bar
Temperature	20 to 275 °F	-30 to 135 °C

Note: For pump operations outside this range, please contact a Ruhrpumpen representative.



VCT

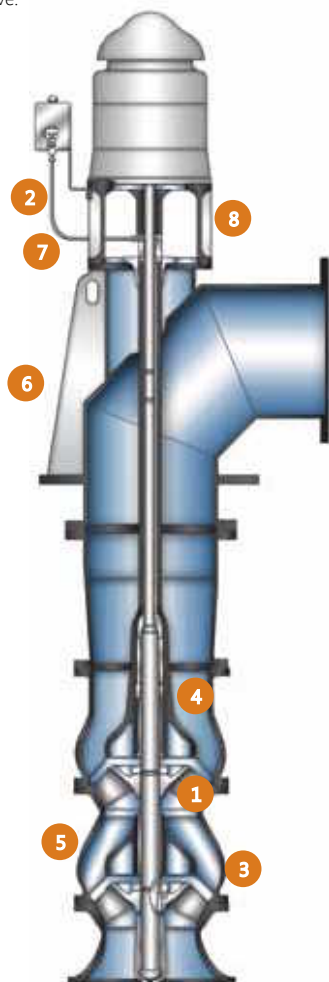

CHARACTERISTICS

- 1 With its mixed flow impeller, this pump handles large volumes of fluids with higher head than axial flow pumps.
 - 2 Oil, fresh water, or self-lube column construction.
 - 3 Wide range of impeller designs and specific speeds (1,800 – 14,000 US units) for optimum hydraulic coverage.
 - 4 Integral bearing retainer.
 - 5 Sizes 20 cm (8 in) to 305 cm (120 in).
 - 6 Above or below ground discharge.
 - 7 Packed stuffing box or mechanical seal.
 - 8 Pump-mounted thrust bearings when required.
- Vertical space-saving construction.
 - Engineered to customer specifications.
 - Optional pull-out design for ease of maintenance.

To see more features of this pump, please see the VCT brochure, or contact a Ruhrpumpen representative.

Additional Ruhrpumpen Pumps for Concentrated Solar Field Applications

DSV



Characteristics

- Single stage vertical, centrifugal, twin volute pump (type VS2).
- Double suction enclosed impeller.
- Counter clockwise rotation viewed from shaft.
- Available as a low NPSH first-stage for other vertical models.

Application

- Cooling Towers.

Performance Range

US Units:
 Q: 1,500 to 80,000 gpm
 H: 40 to 800 ft
 Temp: 32 to 302 °F
 Pd: up to 285 psi
 Discharge flange size: 12" to 36"

Metric Units:
 Q: 40 to 18,170 m³/h
 H: 12 to 244 m
 Temp: 0 to 150 °C
 Pd: up to 20 bar
 Discharge flange size: 305 mm to 915 mm

HSC

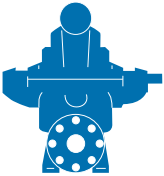

Characteristics

- Single stage, horizontal split case pump (type BB1).
- Double volute.
- Flanged connections.
- Enclosed impellers double suction.

Application

- Circulating Water Pump.

Performance Range

US Units:
 Q: up to 75,000 gpm
 H: up to 550 ft
 Temp: 50 to 300 °F
 Pd: up to 400 psi
 Discharge flange size: 5" to 36"

Metric Units:
 Q: up to 17,040 m³/h
 H: up to 168 m
 Temp: 10 to 150 °C
 Pd: up to 28 bar
 Discharge flange size: 127 mm to 915 mm

ZM

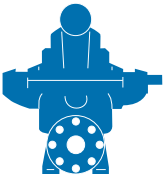

Characteristics

- Axially split, single or double stage pump (type BB1).
- Near-centerline mounted.
- Double volute casing.
- Double suction, radial, closed impeller.
- Side-side inline nozzle.

Application

- Circulating Water Pump.

Performance Range

US Units:
 Q: 4,400 to 61,700 gpm
 H: 30 to 3900 ft
 Temp: -4 to 430 °F
 Pd: up to 2,103 psi
 Discharge flange size: 6" to 32"

Metric Units:
 Q: 100 to 14,000 m³/h
 H: 10 to 1,200 m
 Temp: -20 to 220 °C
 Pd: up to 145 bar
 Discharge flange size: 152 mm to 813 mm

VTP



Characteristics

- Multi-stage vertical centrifugal pump with diffuser type bowl (type VS1).
- Semi-open / enclosed impellers.
- Double suction first stage available.
- Fabrications according to API-610 latest edition available upon request.

Application

- Condensate.

Performance Range

US Units:
 Q: up to 460,000 gpm
 H: up to 2,500 ft
 Temp: 32 to 250 °F
 Pd: up to 1,080 psi

Metric Units:
 Q: up to 13,636 m³/h
 H: up to 762 m
 Temp: 0 to 121 °C
 Pd: up to 74 bar

JTN

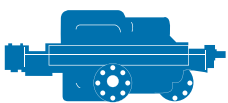

Characteristics

- Axially split, horizontal multi-stage pump (type BB3).
- Near-centreline mounted.
- Diffuser casing.
- Single suction, enclosed impeller.
- Side-side nozzle arrangement.

Application

- Boiler Feed.

Performance Range

US Units:
 Q: 44 to 2,100 gpm
 H: 325 to 3,900 ft
 Temp: -4 to 400 °F
 Pd: up to 1,880 psi
 Discharge flange size: 1 1/2" to 6"

Metric Units:
 Q: 10 to 480 m³/h
 H: 100 to 1,200 m
 Temp: -20 to 200 °C
 Pd: up to 130 bar
 Discharge flange size: 38 mm to 152 mm

SM / SMI



Characteristics

- Multi-stage, axially split casing, centerline mounted horizontal pump (type BB3).
- Side-side suction and discharge nozzles.
- Roller bearings with oil ring bearing lubrication.

Application

- Boiler Feed.

Performance Range

US Units:
 Q: up to 8,800 gpm
 H: up to 5,330 ft
 Temp: -110 °F to 390 °F
 Pd: up to 4,000 psi

Metric Units:
 Q: up to 2,000 m³/h
 H: up to 1,600 m
 Temp: -80 °C to 200 °C
 Pd: up to 276 bar

Reference Project Solar Power Plant ANDASOL III

ANDASOL III, developed by Solar Millennium Group, is a Solar Thermal Power Plant in Spain with a capability of delivering solar electricity to 200,000 homes. The plant relies on Ruhrpumpen pumps to transport the heat transfer fluid through the parabolic troughs.

The Concentrated Solar Power field (CSP) is also able to store energy which allows the plant to generate energy even without sunlight.

Due to the variable operation and the daily starts and stops, along with the temperatures and pressures that needed to be met, Ruhrpumpen selected an API between bearing single stage, horizontal double suction pump to handle the heat transfer fluid which is a synthetic oil.

Chrome steel material was chosen for the casing and impeller. The pumps are equipped with cooling systems, seals, gauges, lubrication systems, and are driven by electric motors and variable frequency drives.



Order Number	Pump Type	Customer	Fluid	Flow	Head	Temperature	Speed
182504	HVN 12X17	Solar Millennium Group	Synthetic Oil	7,032 gpm (1,600 m ³ /h)	951 ft (290 m)	Up to 750 °F (400 °C)	3356 RPM

Reference Project Solar Two Project

Solar Two Project, developed by Bechtel, consisted of a 10 MW Concentrated Thermal Solar Power Plant in California's Mojave Desert. The plant had a solar power tower surrounded by heliostats that reflected the sun light to the top of the tower.

The plant used molten salt as an energy storage medium. The molten salt allowed the energy to be stored in large tanks for future use such as night time. Ruhrpumpen, in 1994, supplied the VLT molten salt pumps required for the Solar Two Project.

The molten salt pumps provided by Ruhrpumpen had special ribs to support the columns. The fluid bled back to the sump so the seal area would not see the molten salt except for an upset condition. Other characteristics of this pump was that the stuffing box had packing installed and not a seal and metal "C" rings were used in lieu of o-rings.

Newer technology of molten salt pumps as of concentrated solar power fields had led Ruhrpumpen to develop newer pumps for these applications, and we have the pumps for the most modern fields.



Order Number	Pump Type	No. Stg.	Customer	Fluid	Flow	Head	Speed
2194B-MP-001A-PO	700 VLTF	9	Bechtel Solar Two Project	Molten Salt	443 gpm (100 m3/h)	443 gpm (100 m3/h)	3550 RPM

Other Ruhrpumpen Products



ANSI Horizontal Process Pump

Single stage, radially split casing with flanged connections, enclosed impeller, foot mounted. Petrochemical, Oil & Gas, Steel Industry, Automotive, Power Generation, Water Treatment, Pharmaceutical and General Process.



Sump Pump

Vertical arrangement, single suction, single stage. Water, Hydrocarbons and Chemical Solutions.



Volute Casing Centrifugal Pump

Axially split, horizontal single or double stage, double volute casing, double suction, radial, closed impeller. Pipeline Service-Mainline and Booster, Oil Extraction, Refinery, Chemical, Petrochemical, Metallurgical and Power Stations.



Fire Pump







Horizontal Split case, listed by Underwriters Laboratories Inc. and approved by Factory Mutual. Commercial Centers, High Rise Buildings, Onshore/Offshore Platforms, Power Stations and Chemical Industries.



With every project you can count on **QUALITY, SERVICE, EXPERTISE, INNOVATION** and **COMPETITIVENESS**.
Because we have a commitment to each customer, the community, and the world.
We are Ruhrpumpen, the specialist for pumping technology!



RUHRPUMPEN PLANTS

-  GERMANY, Witten
-  USA, Tulsa & Orland
-  MEXICO, Monterrey
-  EGYPT, Cairo
-  INDIA, Chennai
-  BRAZIL, Rio de Janeiro
-  ARGENTINA, Buenos Aires

More Information:

